



AIR UNIT OWNER'S MANUAL

Installation, Operation and Maintenance

IMPORTANT: Anyone responsible for installation, maintenance or operation of this equipment must have a thorough understanding of the instruction and safety before attempting to install or service this unit.

Visit our Website at:
www.uvsuperstore.com
E-mail address: info@uvsuperstore.com

AIR DISINFECTION UNIT



INSTALLATION TIPS

- 1. Air disinfection units should be mounted horizontally when installed on a tank top, and vertically when installed on a tank side. It is highly recommended that the system be mounted to the top of the tank as shown in “TYPICAL AIR DISINFECTION INSTALLATION” drawing in this manual.**
- 2. Units may be mounted directly to the tank, or remotely with interconnection piping.**
- 3. When using interconnection piping, keep the length and directional changes to a minimum. Maximum piping should be kept to a total of no more than ten feet.**
- 4. Units may be installed indoors or outdoors. Indoor installations are preferred to keep temperature differentials to a minimum, thereby avoiding excess condensation.**
- 5. Locate the unit vertically with the filter (air inlet) facing down in areas where wash downs may flood the filter.**
- 6. Locate the unit vertically with filter facing down to avoid filter deterioration from direct sunlight.**
- 7. Locate the air disinfection unit so as to avoid overflow from tank flooding the unit. This can usually be accomplished by mounting the fan powered air unit on a line separate from the tank overflow.**
- 8. Standard piping connection to the fan powered air unit and the non-powered vent is 3 inch IPS. This connection is available in both screw threaded and sanitary tri-clamp styles.**
- 9. Electrical connection is made direct to the terminal strip in the fan powered air unit. Units are available in 120V/60HZ/1Ø and 220V/50HZ/1Ø.**
- 10. Off-On control panel box with indicator pilot lamps should be located in a visible and easily accessible area. Indicator pilot lamps show operation of UV lamps and fan.**
- 11. Optional lamp out contacts and blower failure contacts available.**

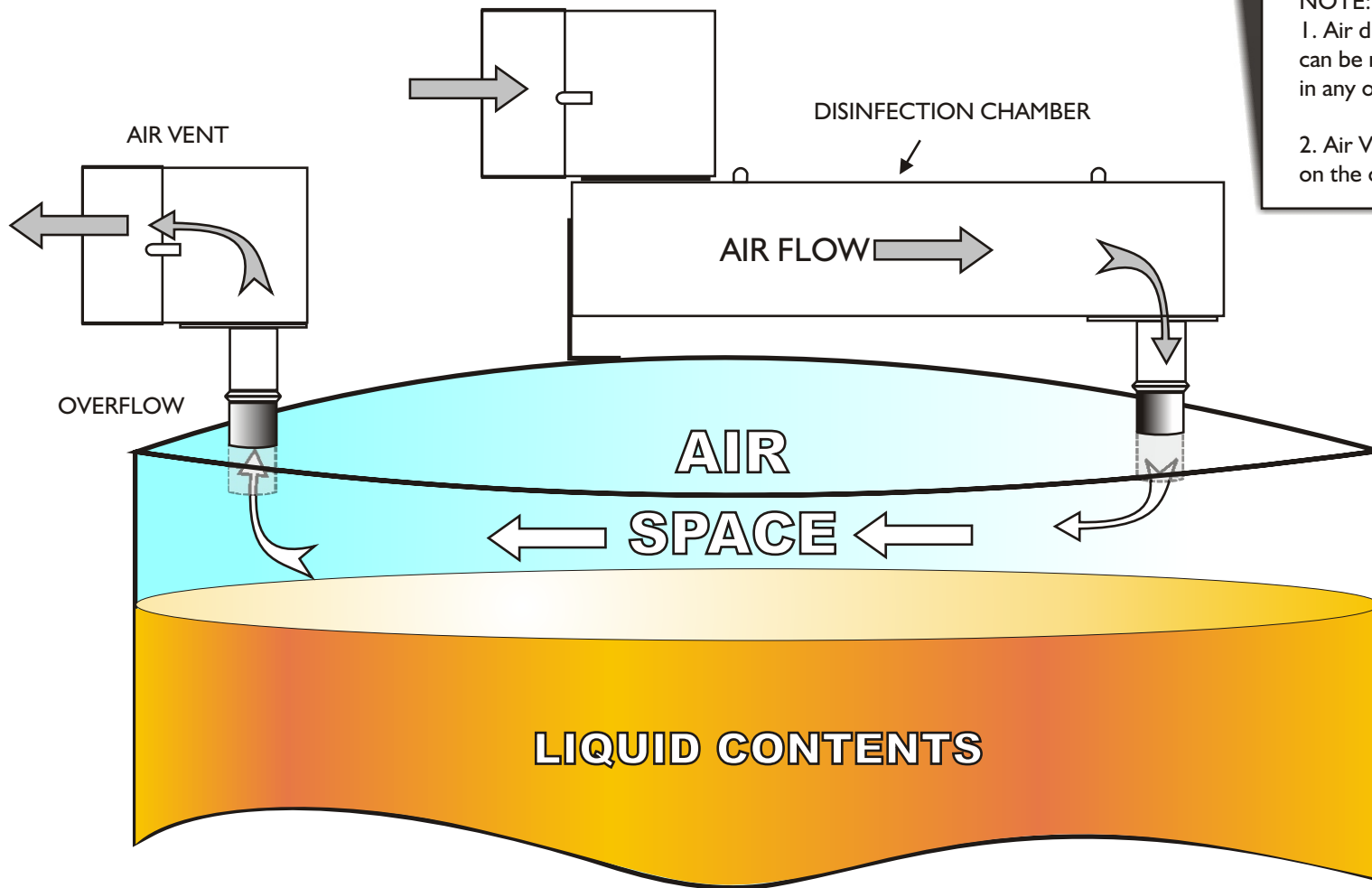

NOTE:

1. Air disinfection unit can be mounted in any orientation.
2. Air Vent is mounted on the overflow pipe.

CONFIDENTIALITY NOTICE

The information contained in this drawing is owned by UV SuperStore. Unauthorized copying or other reproduction is strictly prohibited.



DESCRIPTION:
TYPICAL AIR DISINFECTION INSTALLATION

DRAWN BY: BR	DATE: 11/05
CHECKED BY: BE	DATE: 8/11/05
APPROVED BY:	DATE:
SCALE (8' x 11'):	NONE
	LOG NUMBER:

QUOTE NO.	
DWG NO.	REV.

AIR DISINFECTION UNIT

ASSEMBLY

The Air Disinfection Unit is shipped disassembled and will require minor assembly at time of installation. The component parts are:

- Disinfection Chamber
- Filter-Blower Box
- Filter-Vent Box
- Control Panel
- Piping Connection Fittings (2)
- Hardware Package

DISINFECTION CHAMBER

This cabinet contains the ultraviolet lamps and the terminal strip for “Power-In” and “Control” terminations. This cabinet has mechanical connections for the filter-blower box and for piping connection fitting.

FILTER-BLOWER BOX

This box contains the blower (fan) for the system along with two (2) washable electrostatic filters and one (1) H.E.P.A. filter. This box mounts on top of the disinfection chamber. The power wire for the blower is fed through to the terminal strip.

PIPING CONNECTION FITTING

The piping connection fitting is 3” IPS. This fitting is supplied in sanitary tri-clamp configuration as a standard. Optional screw thread configuration can be supplied upon request. One each is to be connected on the disinfection chamber and the filter-vent box.

FILTER-VENT BOX

The filter-vent box contains two (2) washable electrostatic filters and one (1) H.E.P.A. filter.

CONTROL PANEL

The control panel contains the Start/Stop push button and indicator lamps for “Blower On”, “Lamp 1 On”, and “Lamp 2 On”. Field wiring will be required between the control panel and the terminal strip in the disinfection chamber.

HARDWARE PACKAGE

The hardware package contains nuts, bolts, and washers for assembly of:

- Filter-Blower Box to Disinfection Chamber
- Piping Fitting to Disinfection Chamber

- Piping Fitting to Filter-Vent Box

AIR DISINFECTION UNIT

OPERATION

TO START UNIT

1. Press and hold Start/Stop button for 5-10 seconds, then release.
2. All indicator lights on control panel should remain lit after release of start button.

TO STOP UNIT

1. Press and hold Start/Stop button for 5-10 seconds, then release.
2. All indicator lights on control panel should now be off.

INDICATOR LAMPS OUT

1. If either UV lamp fails, the corresponding indicator lamp will turn off.
2. If the blower fails, or the filters are clogged, the corresponding indicator lamp will turn off. Additionally, the system will shut down due to low airflow.

UV LAMP REPLACEMENT

1. UV lamps should be replaced every 8,000 hours of running time. This is approximately every 12 months.
2. Turn off power to the unit to replace the lamps.

FILTER REPLACEMENT

1. Filters need to be replaced based on the amount of contaminants in the air being captured.
2. Washable electrostatic filters can be cleaned by reverse flow washing and soaking.
3. H.E.P.A. filters are not washable.
4. Minimum suggested maintenance is once a year at time of lamp change.

AIR DISINFECTION UNIT

REPLACEMENT PARTS

120V/60HZ/1Ø

220V/50HZ/1Ø

UNIT MODEL: UV-SC-2AB/10SS

PART NUMBER	DESCRIPTION	NUMBER REQUIRED
FLT-025	Electrostatic Filter	4
FLT-035-3	H.E.P.A. Filter	2
292672	Germicidal UV Lamp	2
G36-3084-PTFE	Germicidal UV Lamp Shatter Proof	2
4C446	146 CFM Fan 120V/60HZ	1
1TDP6	130 CFM Fan 230V/50/60HZ	1
16518MV-UV-NC	Ballast 120V-240/60HZ/1Ø	1
4-0200-UV-NB	Lamp Socket	4

UV SuperStore, Inc.

820 Tucker Court

Winder, GA 30680

Tel: (770) 307-3882 / Fax: (770) 307-3872

E-Mail: info@uvsuperstore.com

Visit our website at:

www.uvsuperstore.com

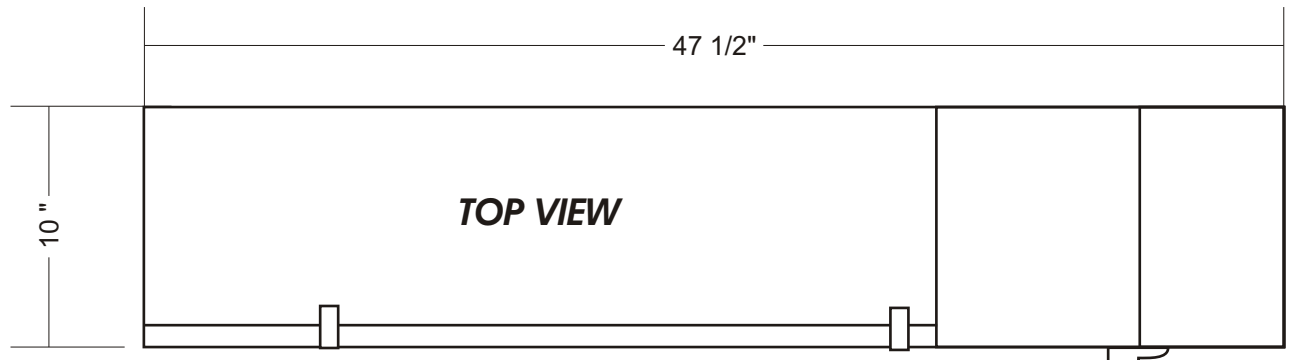
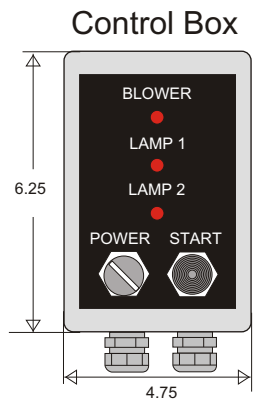

Filter/Blower Housing

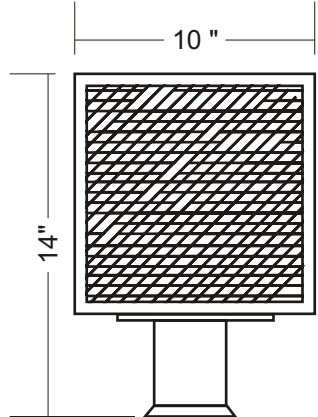

Filter/Vent Housing

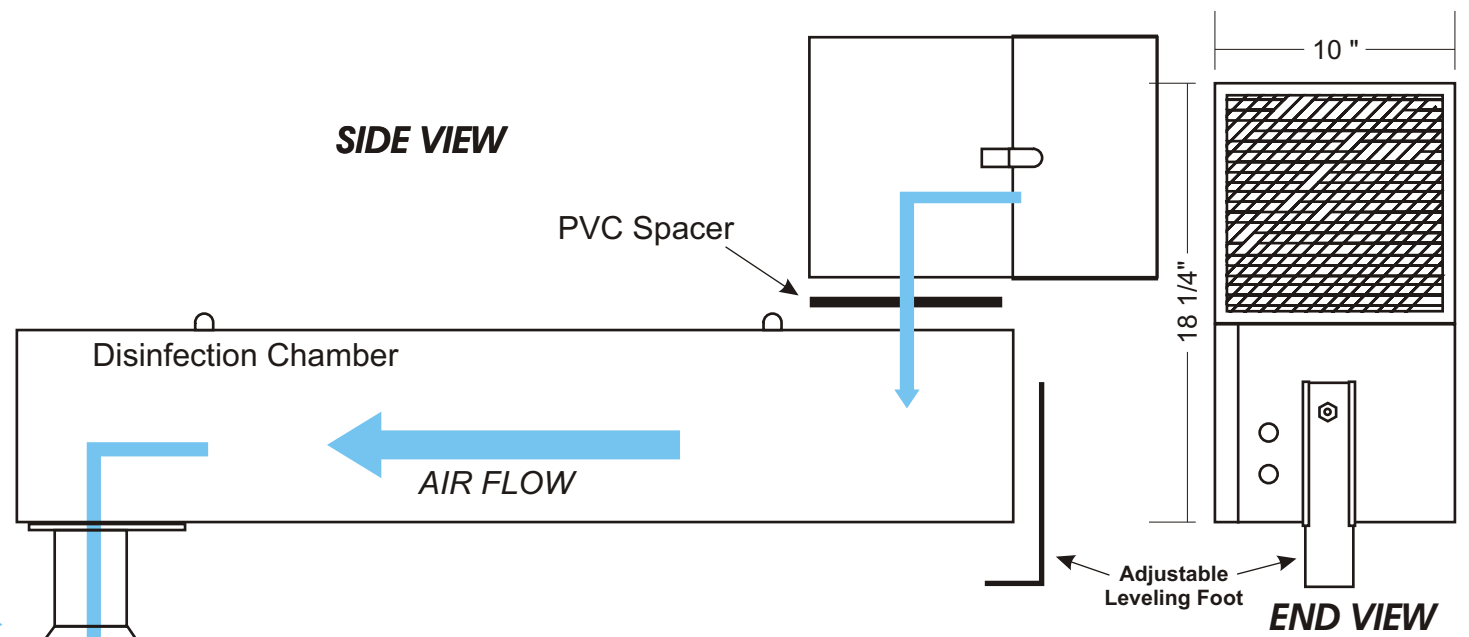

3 "Ø x 3" [standard]
3"NPT [optional]

CONFIDENTIALITY NOTICE
The information contained in this drawing is owned by UV Superstore. Unauthorized copying or other reproduction is strictly prohibited.

UV SUPERSTORE
820 Tucker Court Winder, GA 30680
Tel 770.307.3882 www.uvsuperstore.com

DESCRIPTION: Tank Vent/Filter/Disinfection		QUOTE NO.	
DRAWN BY:	DATE:		
CHECKED BY:	DATE:		
APPROVED BY:	DATE:	DWG NO. UV-805	REV.
SCALE (8"/X11):	LOG NUMBER:		

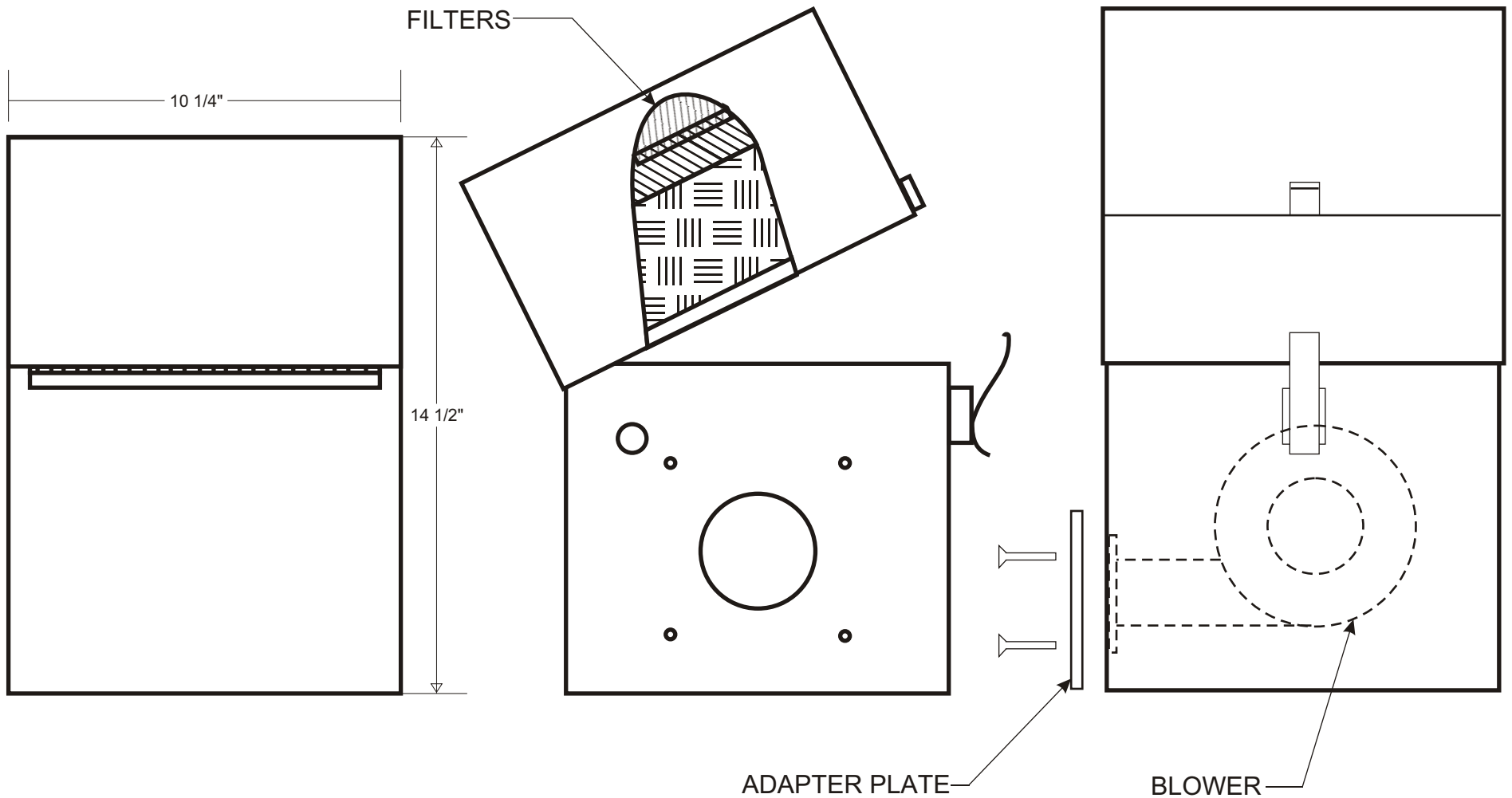

CONFIDENTIALITY NOTICE
 The information contained in this drawing is owned by UV Superstore. Unauthorized copying or other reproduction is strictly prohibited.



DESCRIPTION: OUTLINE, BLOWER/ FILTER BOX		QUOTE NO.	
DRAWN BY: BR	DATE: 8/18/05		
CHECKED BY:	DATE:	DWG NO.	REV.
APPROVED BY:	DATE:	UV-1490	
SCALE (8 1/2" X 11"):	1:4	LOG NUMBER:	

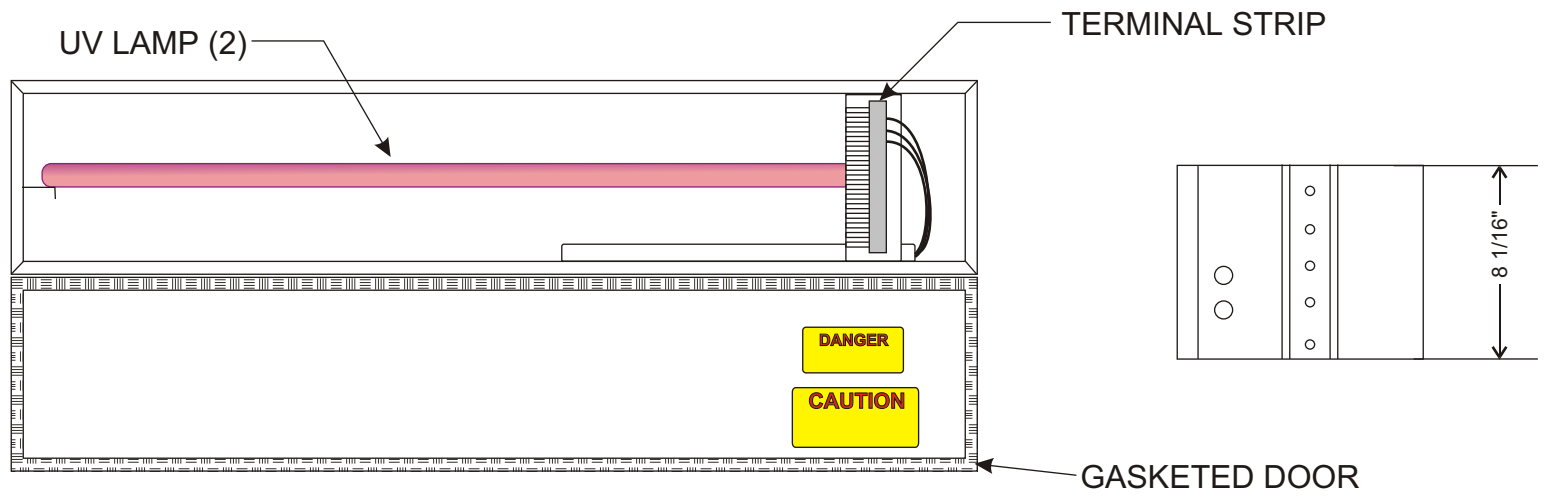
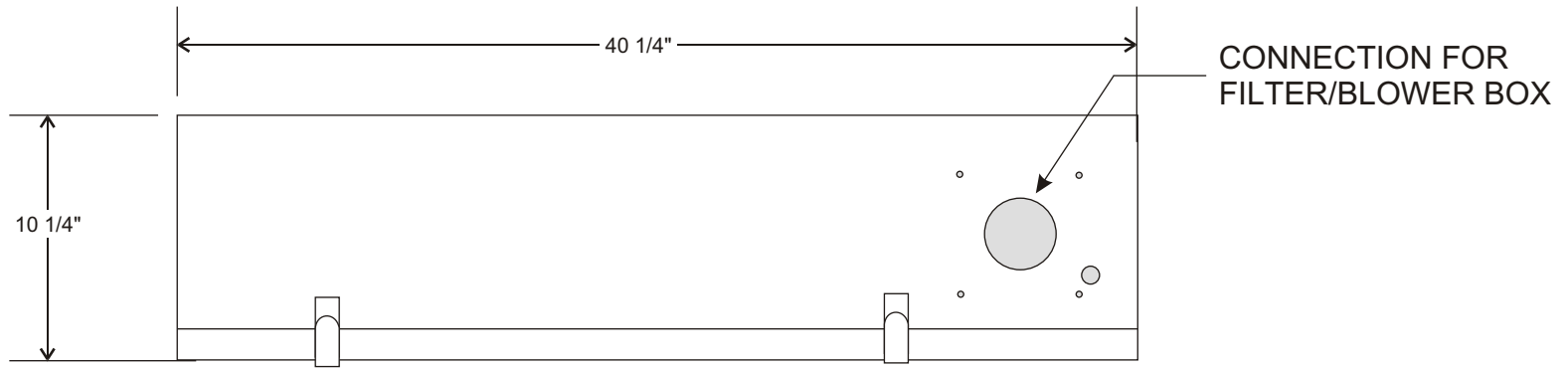

CONFIDENTIALITY NOTICE
 The information contained in this drawing is owned by UV Superstore. Unauthorized copying or other reproduction is strictly prohibited.



820 Tucker Court Winder, GA 30680
 Tel 770.307.3882 www.uvsuperstore.com

DESCRIPTION: OUTLINE, UV AIR UNIT, BASIC UNIT		QUOTE NO.	
DRAWN BY: BR	DATE: 8/18/05		
CHECKED BY:	DATE:	DWG NO.	REV.
APPROVED BY:	DATE:	UV-1482	
SCALE (8 1/2" X 11): 1:8	LOG NUMBER:		